

永茂建机  
YONGMAO

STT113  
6t

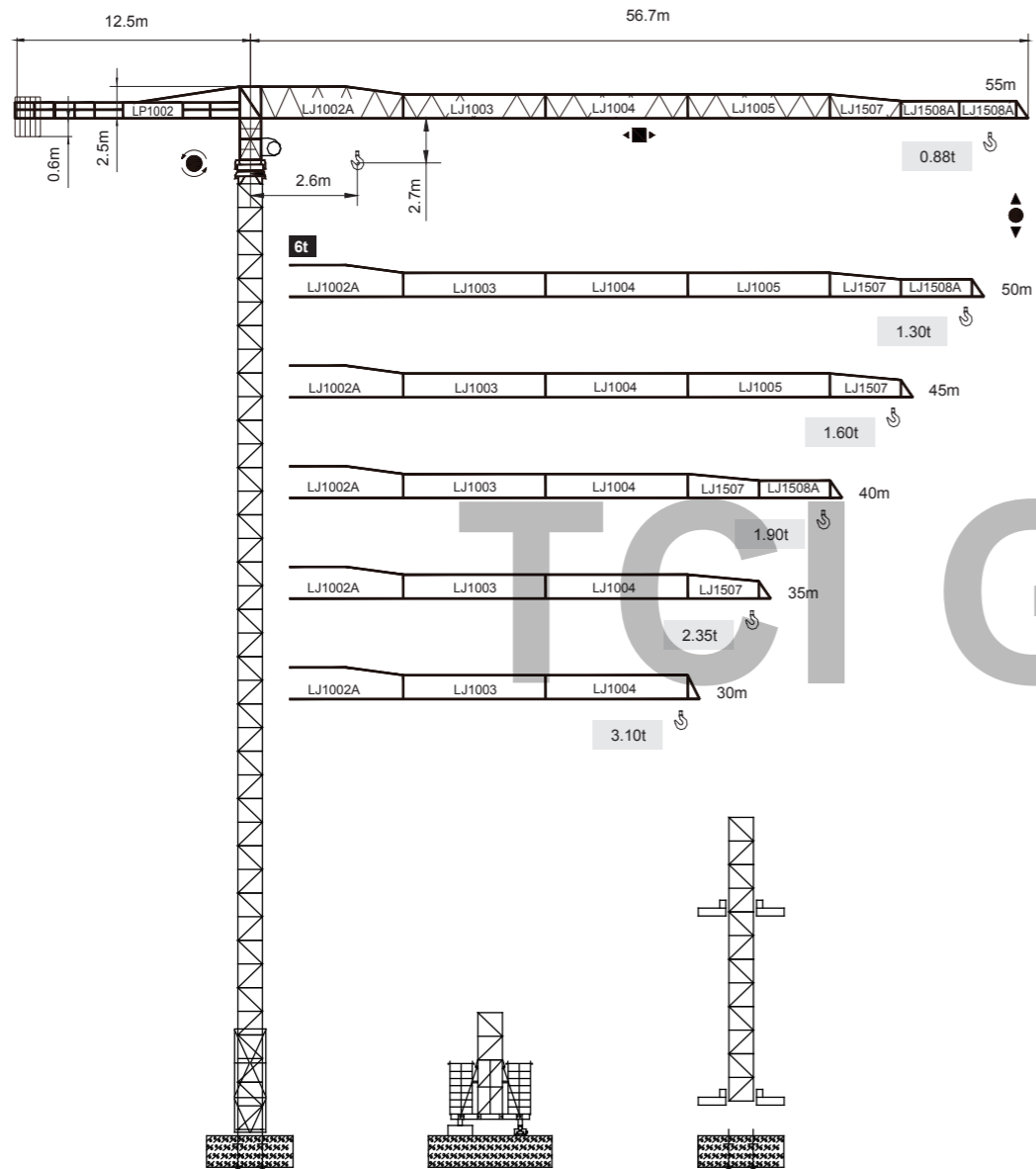

CE FEM

Topless

V 5.0-09012016

平頭系列

STT113  
6t

載荷表 Load Chart

R (m)	倍率 Fall	R (C <sub>max</sub> ) (m)	C <sub>max</sub> (t)	25	30	35	40	45	50	55
55	☹	12.37	6.00	2.57	2.03	1.65	1.37	1.15	0.97	0.83
	☺	22.29	3.00	2.61	2.07	1.69	1.41	1.19	1.02	0.88
50	☹	14.43	6.00	3.13	2.49	2.05	1.71	1.46	1.25	
	☺	26.18	3.00	3.00	2.54	2.09	1.76	1.50	1.30	
45	☹	15.06	6.00	3.30	2.64	2.17	1.82	1.55		
	☺	27.38	3.00	3.00	2.68	2.22	1.87	1.60		
40	☹	15.24	6.00	3.35	2.68	2.20	1.85			
	☺	27.72	3.00	3.00	2.73	2.25	1.90			
35	☹	15.75	6.00	3.49	2.79	2.30				
	☺	28.67	3.00	3.00	2.84	2.35				
30	☹	17.12	6.00	3.86	3.10					
	☺	30.00	3.00	3.00	3.00					

R-6-A(B)-2-V1.0

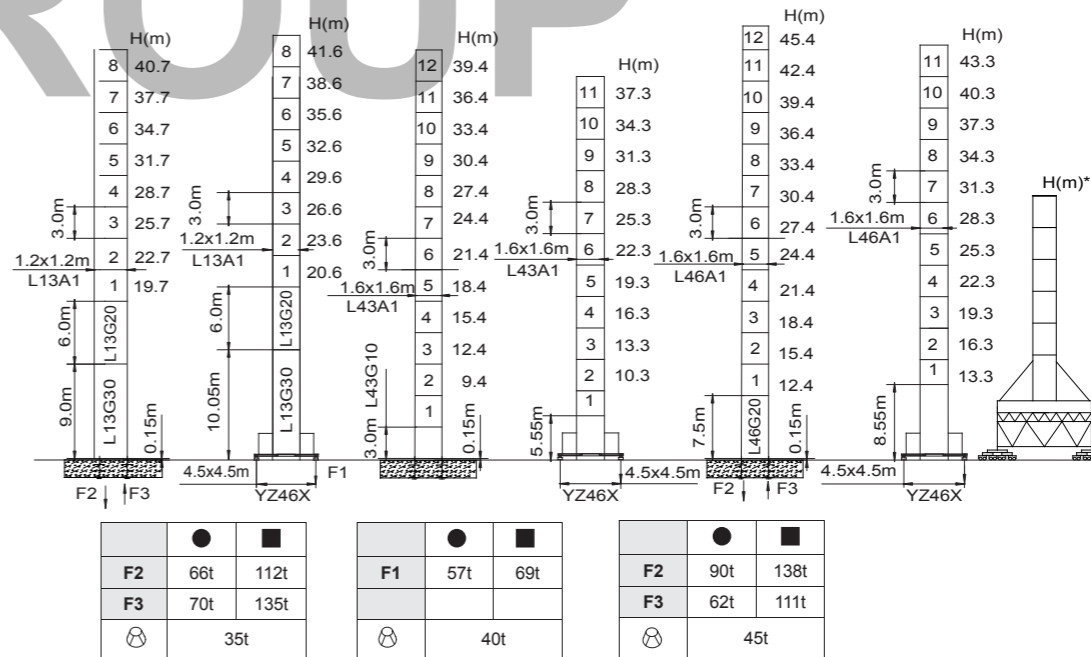
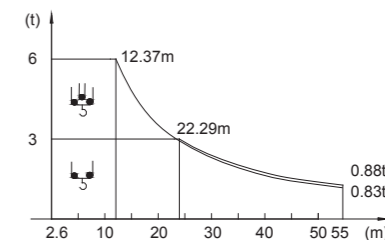

● 工作狀態支反力 In service reaction ■ 非工作狀態支反力 Out of service reaction  
⊗ 整機自由高度重量 (不含平衡重及壓重重量) Total weight of free standing crane (excludes counter weight & ballast)

Topless STT113

0 0  
4 5  
9 0

Topless STT113  
Topless STT113



YONGMAO HOLDINGS LIMITED



YONGMAO HOLDINGS LIMITED

# STT113

## 6t

平頭系列

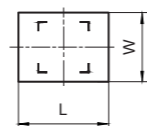
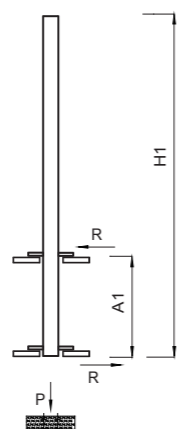
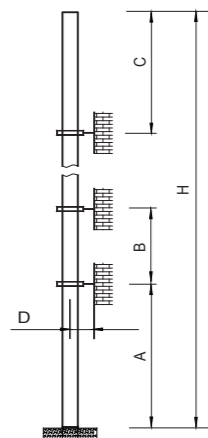

內爬框外廓尺寸  
Overall dimensions of the internal climbing frame

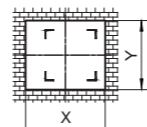

內爬開口尺寸  
Dimensions of the internal climbing opening

塔身節 Mast	A (m)	B (m)	C (m)	D (m)	H (m)
L46A1	36	27	32.8	>3.2	200 >200*
L13A1	28.5	18	23.8	>3	180 >180*

塔身節 Mast	H1 (m)	A1 (m)	P (t)	R (t)	X (m)	Y (m)	L (m)	W (m)
L46A1	53.9	16	78	20	3.28	2.4	3.5	3.02
L13A1	29.61	12	50	18	2.58	2.17	2.78	3.29

附著道數 Number of tie collars  $= (H-A-C)/B+1$

超過100m高度，需降低載荷，請與公司聯繫。

Load should be reduced when the height exceeds 100m. Please contact Yongmao for details.

主要性能參數 Specifications

機構 Mechanism	↑		↓		電動機 Motor kW		
	m/min	t	m/min	t			
▲ ▼	24YQL15 ☆	0-8.0	3.0	0-4.0	6.0	390m	24/24/5.4
		0-40	3.0	0-20	6.0		
		0-80	1.5	0-40	3.0		
◀ ▶	24PQC15	0-8.5	3.0	0-4.2	6.0	400m >400m*	24/24/6
		0-40	3.0	0-20	6.0		
		0-80	1.5	0-40	3.0		
↔	DTC55	0-57 m/min				55 N·m	
↻	YMD50 ☆	0-0.7 rpm				5	
	RTC95	0-0.7 rpm				95 N·m	
👁	RT	12.5-25 m/min				2x2.6/5.2	

電壓 Pressure	kVA
380V (± 10%) 50 Hz	40

\* 與製造商聯繫 Contact us, please.

☆ 标准配置 Standard configuration.

本技術參數不受法律約束，技術資訊請詳見相應說明書。

These specifications and data are not legally binding. For any technical information, please refer to corresponding instructions.



YONGMAO HOLDINGS LIMITED

Topless STT113

Topless STT113

TCL GROUP

0  
5  
1

0  
5  
2