

永茂建机  
YONGMAO

STL2400C  
100t

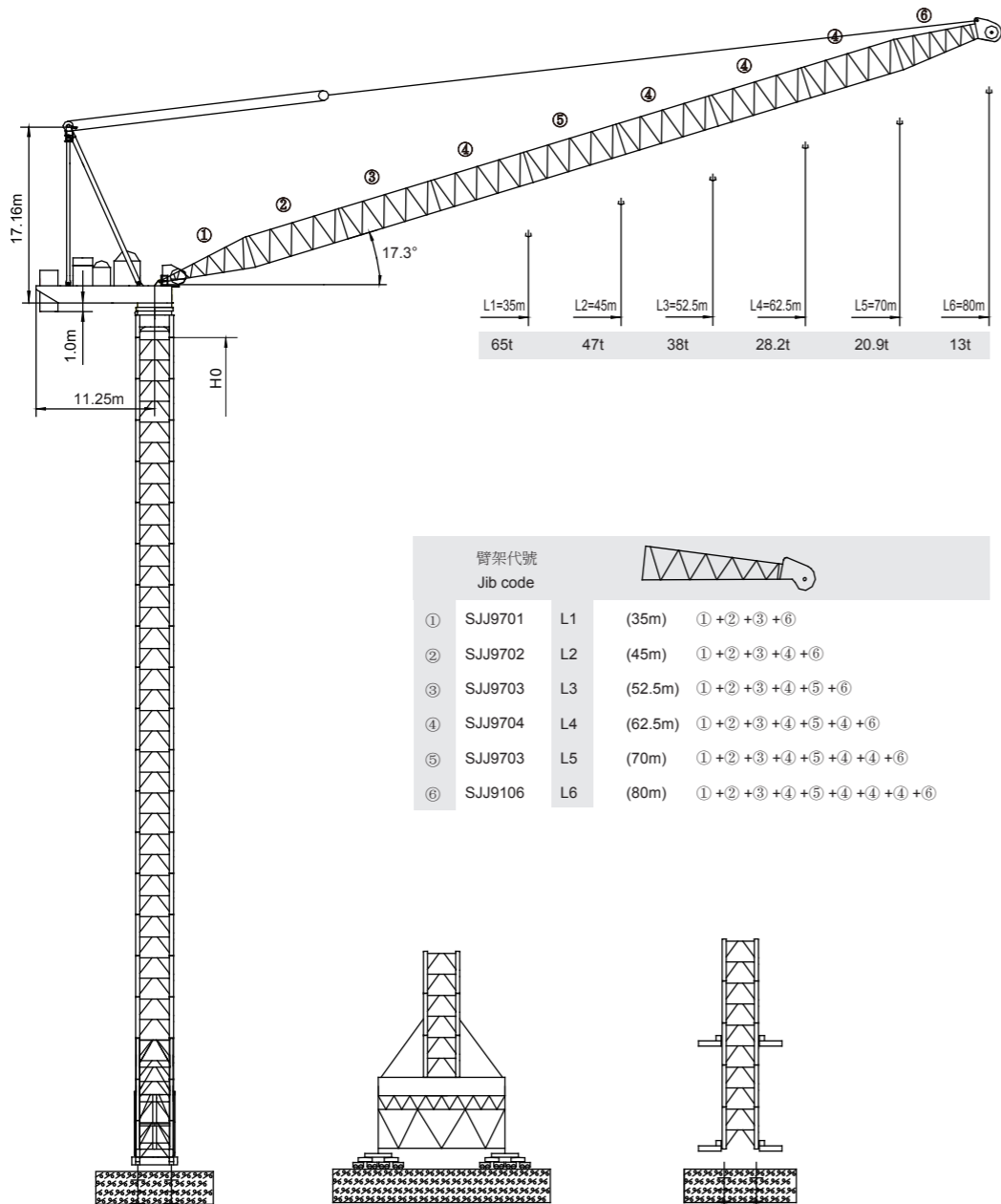

CE FEM

Luffing

V 5.0-09112014

動臂系列

STL2400C  
100t

載荷表 Load Chart

STJ-100-A(B)-1-V1.0

R (m)	倍率 Fall	R(Cmax) (m)	Cmax (t)	25	30	35	40	45	50	52.5	57.5	62.5	65	70	75	80
80	↓	8.7~27.50	50.00	50.00	48.40	45.00	41.20	37.80	34.20	32.40	28.80	25.30	23.50	20.00	16.50	13.00
70	↓	7.9~25.00	80.00	80.00	72.00	64.50	54.50	47.00	40.80	38.10	32.70	27.50	25.00	<b>20.90</b>		
	↓	7.9~42.50	50.00	50.00	50.00	50.00	50.00	47.00	40.80	38.10	32.70	27.50	25.00	<b>20.90</b>		
62.5	↓	7.1~24.50	100.00	98.10	79.00	65.50	55.50	48.00	41.80	39.20	33.80	<b>28.20</b>				
	↓	7.1~42.50	50.00	50.00	50.00	50.00	50.00	48.00	41.80	39.20	33.80	<b>28.20</b>				
52.5	↓	6.3~24.70	100.00	98.90	80.20	66.80	56.80	49.00	42.50	<b>38.00</b>						
	↓	6.3~42.50	50.00	50.00	50.00	50.00	50.00	49.00	42.50	<b>38.00</b>						
45	↓	5.5~24.90	100.00	99.60	81.20	67.90	57.00	<b>47.00</b>								
	↓	5.5~42.50	50.00	50.00	50.00	50.00	50.00	<b>47.00</b>								
35	↓	4.7~25.00	100.00	100.00	81.90	<b>65.00</b>										
	↓	4.7~35.00	50.00	50.00	50.00	<b>50.00</b>										

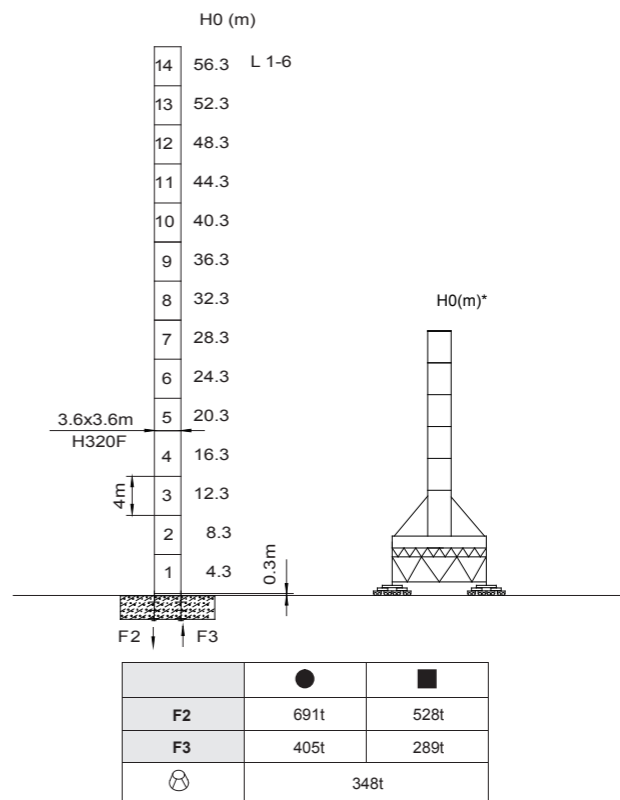
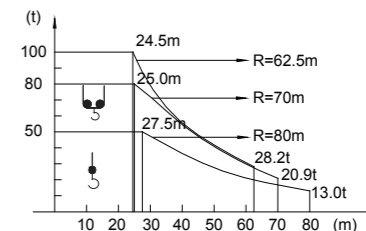

● 工作狀態支反力 In service reaction    ■ 非工作狀態支反力 Out of service reaction  
 ⊕ 整機自由高度重量 (不含平衡重及壓重重量) Total weight of free standing crane (excludes counter weight & ballast.)

Luffing STL2400C

1 1  
4 5  
9 0

Luffing STL2400C  
Luffing STL2400C



YONGMAO HOLDINGS LIMITED



YONGMAO HOLDINGS LIMITED

# STL2400C 100t

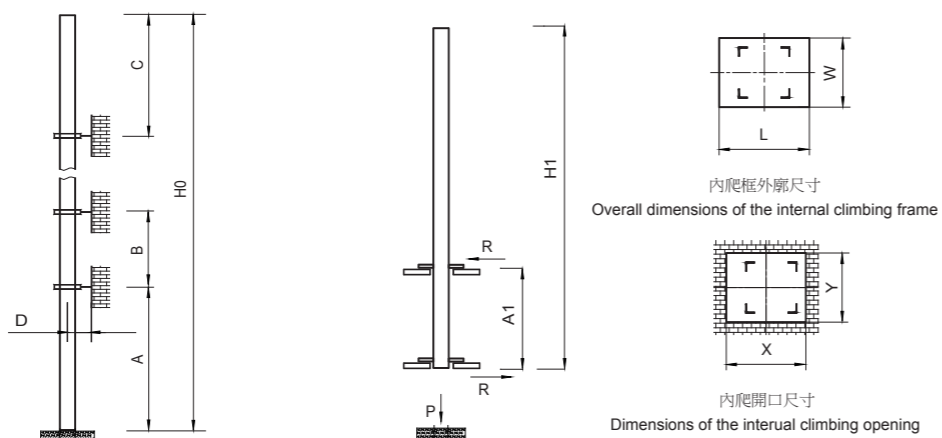

塔身節 Mast	臂長 Jib length	A (m)	B (m)	C (m)	D (m)	H0 (m)
H320F	L1-6	42.3	34	48	>5	400 >400*

塔身節 Mast	臂長 Jib length	H1 (m)	A1 (m)	P (t)	R (t)
H320F	L1-6	56	17	555	145
		X (m)	Y (m)	L (m)	W (m)
		4.92	4.0	4.93	4.5

附著道數 Number of tie collars=(H0-A-C)/B+1

超過100m高度，需降低載荷，請與公司聯繫。

Load should be reduced when the height exceeds 100m. Please contact Yongmao for details.

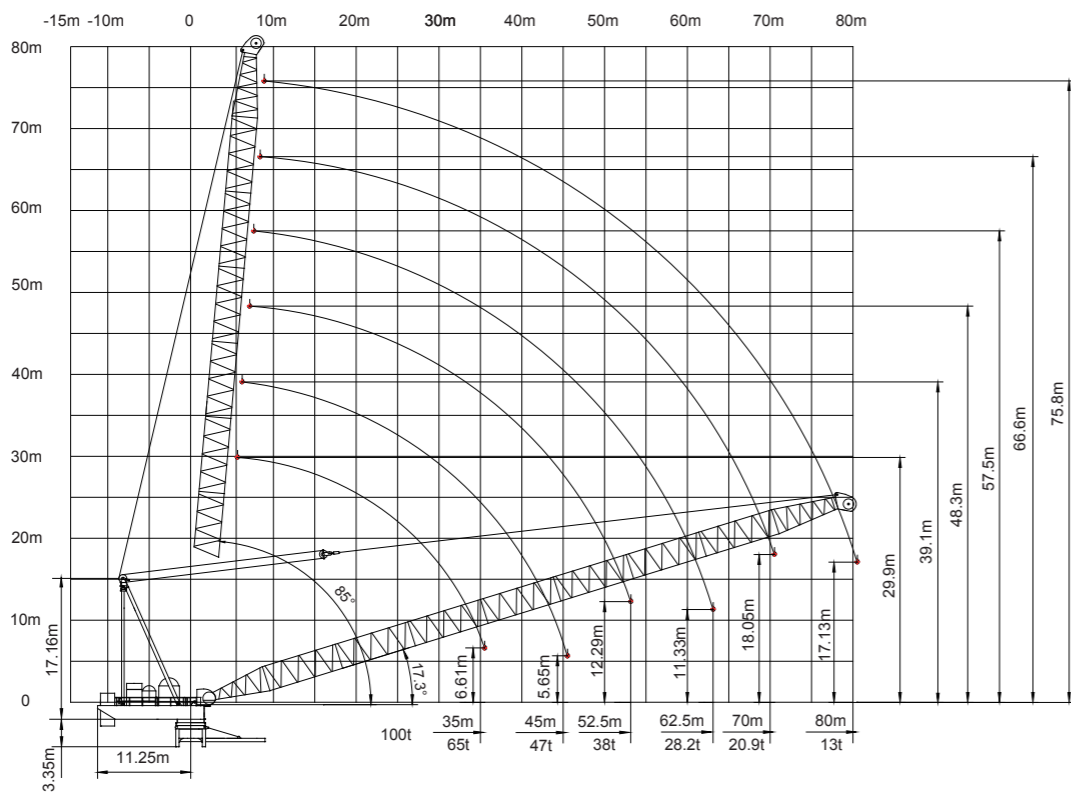

# 動臂系列

# STL2400C 100t

主要性能參數 Specifications

機構 Mechanism	●		⌋		621 m >621m*	功率 Power 522 kW (700hp)
	m/min	t	m/min	t		
4200LYS500	0 - 30 0 - 36 0 - 70 0 - 110	50.0 40.0 20.0 0	0 - 15 0 - 18 0 - 35 0 - 55	100.0 80.0 40.0 0		
3160DYS220	15° - 85° 2 min					
263RYS	0 - 0.75 rpm					
RT	*					*

供電容量 Power supply	kVA
380V (±10%) 50Hz	40

\* 與製造商聯繫 Contact us, please.

☆ 标准配置 Standard configuration.

1  
5  
1

Luffing STL2400C  
Luffing STL2400C



YONGMAO HOLDINGS LIMITED



YONGMAO HOLDINGS LIMITED